

DIESEL ENGINE-GENERATOR SET

AIR CHARGE-AIR COOLING

60 kWe / 60 Hz / Standby
51 kWe / 60 Hz / Prime
208 - 600V



SYSTEM RATINGS

Standby	DS60D6SGA	DS60D6SDA	DS60D6SPA	DS60D6SJA	DS60D6SRA	DS60D6SNA
Voltage (L-L)	240V	240V	208V	240V	480V	600V
Phase	1	1	3	3	3	3
PF	1.0	1.0	0.8	0.8	0.8	0.8
Hz	60	60	60	60	60	60
kW	60	60	60	60	60	60
kVA	60	60	75	75	75	75
AMPS	250	250	208	180	90	72
skVA@30%						
Voltage Dip	119	130	150	150	198	136
Generator Model	362CSL1604	361CSL1613	361CSL1602	361CSL1602	361CSL1602	361PSL1633
Temp Rise	130°C/27°C	130°C/27°C	130°C/27°C	130°C/27°C	130°C/27°C	125°C/40°C
Connection	12 LEAD ZIG-ZAG	4 LEAD	12 LEAD LOW WYE	12 LEAD HI DELTA	12 LEAD HI WYE	4 LEAD WYE

Prime	DP51D6SGA	DP51D6SDA	DP51D6SPA	DP51D6SJA	DP51D6SRA	DP51D6SNA
Voltage (L-L)	240V	240V	208V	240V	480V	600V
Phase	1	1	3	3	3	3
PF	1.0	1.0	0.8	0.8	0.8	0.8
Hz	60	60	60	60	60	60
kW	51	51	51	51	51	51
kVA	51	51	63.75	63.75	63.75	63.75
AMPS	212.5	212.5	177	153	77	61
skVA@30%						
Voltage Dip	119	128	150	150	140	138
Generator Model	362CSL1604	362CSL1615	361CSL1602	361CSL1602	361CSL1602	361PSL1634
Temp Rise	105°C/40°C	105°C/40°C	105°C/40°C	105°C/40°C	105°C/40°C	105°C/40°C
Connection	12 LEAD ZIG-ZAG	4 LEAD	12 LEAD LOW WYE	12 LEAD HI DELTA	12 LEAD HI WYE	4 LEAD WYE

STANDARD FEATURES

- // EPA Tier 3 Certified
- // Engine-Generator Set Tested to ISO 8528-5 for Transient Response
- // UL2200 Listed, CSA Certified – Offered
- // Accepts Rated Load in One Step Per NFPA 110
- // All engine-generator sets are prototype and factory tested
- // MTU Onsite Energy is a single source supplier
- // Global Product Support
- // 2 Year Standard Warranty
- // 5030HF285 Diesel Engine
 - 3.0 Liter Displacement
 - Electronic Unit Pump Injection
 - 4-Cycle
- // Complete Range of Accessories
- // Engine-generator resilient mounted
- // Generator
 - Brushless, Rotating Field Generator
 - PMG (Permanent Magnet Generator) supply to regulator
 - 300% Short Circuit Capability
 - 2/3 Pitch Windings
- // Digital Control Panel(s)
 - UL Recognized, CSA Certified, NFPA 110
 - Complete System Metering
 - LCD Display
- // Cooling System
 - Integral Set-Mounted
 - Engine Driven Fan

STANDARD EQUIPMENT

// Engine

Air Cleaner
 Oil Pump
 Full Flow Oil Filter
 Fuel Filter with Water Separator
 Jacket Water Pump
 Thermostat
 Exhaust Manifold – Dry
 Blower Fan & Fan Drive
 Radiator – Unit Mounted
 Electric Starting Motor – 12V
 Governor – Electronic Isochronous
 Base – Formed Steel
 SAE Flywheel & Bell Housing
 Charging Alternator – 12V
 Battery Box & Cables
 Flexible Fuel Connectors
 Flexible Exhaust Connection
 EPA Certified Engine

// Generator

NEMA MG1, IEEE and ANSI standards compliance for temperature rise and motor starting
 Sustained short circuit current of up to 300% of the rated current for up to 10 seconds
 Self-Ventilated and Drip-Proof
 Superior Voltage Waveform
 Digital, Solid State, Volts-per-Hertz Regulator
 No Load to Full Load Regulation

Brushless Alternator with Brushless Pilot Exciter
 4 Pole, Rotating Field
 130°C Maximum Standby Temperature Rise
 1 Bearing, Sealed
 Flexible Coupling
 Full Amortisseur Windings
 125% Rotor Balancing
 3-Phase Voltage Sensing
 ±1% Voltage Regulation
 100% of Rated Load – One Step
 3% Maximum Harmonic Content

// Digital Control Panel(s)

Digital Metering
 Engine Parameters
 Generator Protection Functions
 Engine Protection
 SAE J1939 Engine ECU Communications
 Windows-Based Software
 Multilingual Capability
 Remote Communications to our RDP-110 Remote Annunciator
 16 Programmable Contact Inputs
 Up to 11 Contact Outputs
 UL Recognized, CSA Certified, CE Approved
 Event Recording
 IP 54 Front Panel Rating with Integrated Gasket
 NFPA110 Compatible

APPLICATION DATA

// Engine

Manufacturer	John Deere
Model	5030HF285
Type	4-Cycle
Arrangement	5 In-Line
Displacement: L (in ³)	3.05 (186)
Bore: cm (in)	8.6 (3.4)
Stroke: cm (in)	10.5 (4.1)
Compression Ratio	18.2:1
Rated RPM	1,800
Engine Governor	JDEC
Maximum Power: Standby: kWm (bhp)	72 (96)
Maximum Power: Prime: kWm (bhp)	65 (87)
Speed Regulation	±0.25%
Air Cleaner	Dry

// Liquid Capacity (Lubrication)

Total Oil System: L (gal)	11.2 (2.96)
Engine Jacket Water Capacity: L (gal)	2.9 (0.78)
System Coolant Capacity: L (gal)	15.4 (4.08)

// Electrical

Electric Volts DC	12
Cold Cranking Amps Under -17.8°C (0°F)	750

// Fuel System

Fuel Supply Connection Size	3/8" NPT
Fuel Return Connection Size	3/8" NPT
Maximum Fuel Lift: m (ft)	3 (10)
Recommended Fuel	Diesel #2
Total Fuel Flow: L/hr (gal/hr)	82 (21.7)

// Fuel Consumption

	STANDBY	PRIME
At 100% of Power Rating: L/hr (gal/hr)	18.9 (5)	17.4 (4.6)
At 75% of Power Rating: L/hr (gal/hr)	14.4 (3.8)	12.9 (3.4)
At 50% of Power Rating: L/hr (gal/hr)	9.5 (2.5)	8.3 (2.3)

// Cooling - Radiator System

	STANDBY	PRIME
Ambient Capacity of Radiator: °C (°F)	50 (122)	50 (122)
Maximum Allowable Static		
Pressure on Rad. Exhaust: kPa (in. H ₂ O)	0.12 (0.5)	0.12 (0.5)
Water Pump Capacity: L/min (gpm)	100 (26)	100 (26)
Heat Rejection to Coolant: kW (BTUM)	45.5 (2,590)	42.7 (2,430)
Heat Rejection to Air to Air: kW (BTUM)	12.7 (723)	10.52 (598)
Heat Radiated to Ambient: kW (BTUM)	12.8 (728)	10.46 (595)

// Air Requirements

	STANDBY	PRIME
Aspirating: *m ³ /min (SCFM)	5.3 (186)	5.1 (179)
Air Flow Required for Rad.		
Cooled Unit: *m ³ /min (SCFM)	158 (5,570)	158 (5,570)
Air Flow Required for Heat		
Exchanger/Remote Rad. based		
on 25°F Rise: *m ³ /min (SCFM)	47 (1,642)	38 (1,341)

* Air density = 1.184 kg/m³ (0.0739 lbm/ft³)

// Exhaust System

	STANDBY	PRIME
Gas Temp. (Stack): °C (°F)	522 (972)	505 (941)
Gas Volume at Stack		
Temp: m ³ /min (CFM)	13.7 (484)	13 (459)
Maximum Allowable		
Back Pressure: kPa (in. H ₂ O)	7.5 (30)	7.5 (30)
Minimum Allowable		
Back Pressure: kPa (in. H ₂ O)	4 (16)	4 (16)

WEIGHTS AND DIMENSIONS

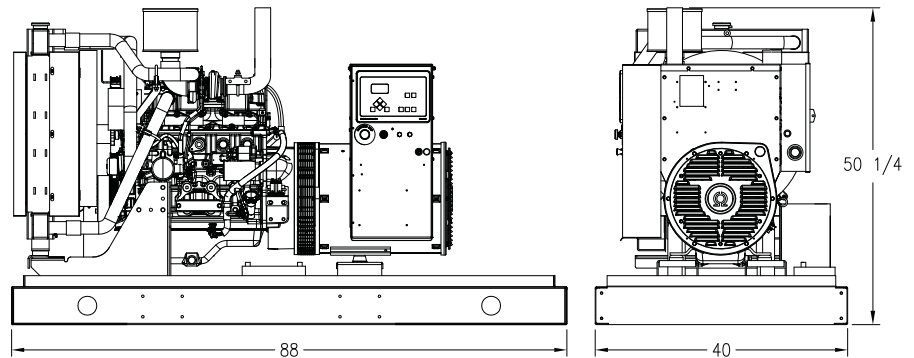

Drawing above for illustration purposes only, based on standard open power 480 volt engine-generator set. Lengths may vary with other voltages. Do not use for installation design. See website for unit specific template drawings.

System	Dimensions (L x W x H)	Weight (dry/less tank)
Open Power Unit (OPU)	2,235 x 1,016 x 1,276 mm (88 x 40 x 50.25 in)	883 kg (1,947 lb)

Weights and dimensions are based on open power units and are estimates only. Consult the factory for accurate weights and dimensions for your specific engine-generator set.

SOUND DATA

Unit Type	Standby Full Load	Prime Full Load
Level 0: Open Power Unit (dBA)	79.2	79.2

Sound data is provided at 7 m (23 ft). Engine-generator set tested in accordance with ISO 8528-10 and with infinite exhaust.

EMISSIONS DATA

NO _x + NMHC	CO	PM
3.4	0.8	0.15

All units are in g/hp-hr and are EPA D2 cycle values.

Emission levels of the engine may vary as a function of ambient temperature, barometric pressure, humidity, fuel type and quality, installation parameters, measuring instrumentation, etc. The data provided are laboratory results from one engine representing this rating. The data was obtained under controlled environmental conditions with calibrated instrumentation traceable to the United States National Bureau of Standards and in compliance with US EPA regulations found within 40 CFR Part 89. The weighted cycle value from each engine is guaranteed to be below the US EPA Standards at the US EPA defined conditions.

RATING DEFINITIONS AND CONDITIONS

- // Standby ratings apply to installations served by a reliable utility source. The standby rating is applicable to varying loads for the duration of a power outage. No overload capability for this rating. Ratings are in accordance with ISO-3046/1, BS 5514, AS 2789, and DIN 6271.
- // Prime power ratings apply to installations where utility power is unavailable or unreliable. At varying load, the number of generator set operating hours is unlimited. A 10% overload capacity is available for one hour in twelve. Ratings are in accordance with ISO-8528/1, overload power in accordance with ISO-3046/1, BS 5514, AS 2789, and DIN 6271.
- // Deration Factor:
 - Altitude:** Consult your local MTU Onsite Energy Power Generation Distributor for altitude derations.
 - Temperature:** Consult your local MTU Onsite Energy Power Generation Distributor for temperature derations.

Materials and specifications subject to change without notice.

C/F = Consult Factory/MTU Onsite Energy Distributor